



**FIM RACING HOMOLOGATION PROGRAMME FOR HELMETS  
(FRHPhe)**

## **Homologation manual n. FRHPhe-01**

October 2019  
Amendments in red colour



GLOSSARY .....	3
I. FOREWORD.....	5
II. SCOPE.....	6
III. TECHNICAL INFORMATION AND CRITERIA (FIM HELMET STANDARD) .....	6
III.1 ELIGIBLE HELMETS.....	6
III.2 TESTING PROCEDURES .....	7
IV. TERMS AND CONDITIONS .....	16
IV.1 APPLICATION.....	16
IV.2 DATA PROTECTION.....	18
IV.3 INTELLECTUAL PROPERTY RIGHTS.....	18
IV.4 TESTING .....	19
IV.5 GRANTING OF THE HOMOLOGATION .....	19
IV.6 LABELING .....	20
IV.7 POST-HOMOLOGATION CONTROLS.....	21
IV.8 INVOICING.....	21
IV.9 WARRANTIES REGARDING ENVIRONMENTAL RESPONSIBILITY AND COMPLIANCE WITH LABOUR, HEALTH AND SAFETY REGULATIONS .....	21
IV.10 INDEMNITIES AND LIABILITY .....	22
IV.11 INSURANCE .....	23
IV.12 WITHDRAWAL.....	23
IV.13 CONSEQUENCES OF WITHDRAWAL .....	23
IV.14 ANNOUNCEMENT.....	24
IV.15 TRANSPARENCY.....	24
IV.16 APPLICABLE LAW AND ARBITRATION .....	24
V. APPLICATION FORM (HOMOLOGATION) / FRHPhe-01 .....	26
VI. APPLICATION FORM (UPDATE) / FRHPhe-01 .....	30

## GLOSSARY

<b>FRHP (FIM Racing Homologation Programme)</b>	FIM Programme that grants recognition to products related to safety and required for competitions.
<b>FRHPhe (FIM Racing Homologation Programme for helmets)</b>	FIM Programme that grants recognition to helmets that meet the FIM Helmet Standard.
<b>FIM Racing Homologation</b>	Confirmation issued by the FIM as an official specification of performance for products related to safety and required for competitions.
<b>FIM Helmet Standard</b>	Ensemble of testing methods and corresponding performance criteria through which helmets are granted a FIM Racing Homologation.
<b>Applicant</b>	Legal entity applying for the FRHPhe and representing the trademark. The applicant shall be the company that markets the helmet to its end-users through customary sales channels (wholesalers/retailers/direct sales) or sells and/or supplies the helmet to competitors and teams. The Applicant may, and in many cases will, also be a helmet manufacturer.
<b>Homologation Manual</b>	Formal document that provides the Technical information and criteria, the Terms and Conditions and the Application Form of the FRHPhe. The Homologation Manual, duly filled in, signed and returned by the Applicant to the FIM, represents the official application to the FRHPhe.
<b>Application Form (homologation or update)</b>	Part of the Homologation Manual, to be completed by the Applicant while applying for the FRHPhe.
<b>(Helmet) Model</b>	Helmet of a certain name/design/shape/material.
<b>(Helmet) Size</b>	Suggested head circumference (expressed in cm) that ideally fits the helmet inner diameter.
<b>(Helmet) Combination of accessories</b>	Helmet configuration obtained with one or more external helmet accessories (e.g. aerodynamic devices, ventilation appendices).
<b>Helmet Sample</b>	Particular unit of a Helmet Model, of a certain Size and with a certain Combination of accessories.
<b>Testing Laboratory</b>	Private or public entity that has received an assignment from the FIM to perform tests according to a certain Homologation Manual and for the FRHPhe.
<b>Test Report</b>	Document issued by the Testing Laboratory that contains the test results relatively to a specific Application Form.

<b>Homologation Notice</b>	Formal document that expresses the granting of the homologation and sets out the rights licensed by the FIM.
<b>Homologation Emblem</b>	Emblem issued by the FIM together with the Homologation Notice. It includes the Applicant logo, the FIM logo, the FRHP logo, the category of product (Helmets), the Helmet Model and Size and the Homologation Manual of reference.
<b>Homologation Refusal</b>	Formal letter transmitted by the FIM to the Applicant in the event that homologation is not granted to an Applicant for a particular helmet.
<b>Homologation Labels</b>	Official labels provided by the FIM to the Applicant once homologation is granted.
<b>Homologation Label cost</b>	Fee associated with the purchase of official labels from the FIM related to the FRHPhe.
<b>Intellectual Property Rights</b>	All trademarks, trade and business names, patents, copyright (including copyright in a computer program), database rights, design rights, registered designs, utility models, semi-conductor topography rights, inventions, know-how, confidential information and all other intellectual property and rights of a similar or corresponding nature in any part of the world, whether or not registered or capable of registration, in respect of such rights which are registrable and all applications for registration of any of the foregoing rights.
<b>Personal Data</b>	Any information relating to an identified or identifiable natural person; an identifiable natural person is one who can be identified, directly or indirectly, in particular by reference to an identifier such as a name, an identification number, location data, an online identifier or to one or more factors specific to the physical, physiological, genetic, mental, economic, cultural or social identity of that natural person.

## I. FOREWORD

Until now, the FIM has referred solely to existing international standards for the approval of helmets for use in its competitions.

In order to take account of a more complete and demanding evaluation of performance, and give specific and exclusive recognition to helmets that meet more demanding criteria, the FIM Technical and Circuit Racing Commissions have now launched a pioneering and unique programme, the FIM Racing Homologation Programme for helmets (FRHPhe), which features the latest state of art methods of testing.

Under this programme, the FIM will grant helmets a homologation certificate and labels, which will be a mandatory prerequisite to be entitled to access FIM Circuit Racing competitions.

To obtain such homologation, the helmet will have to meet the high performance and quality standard set by the FIM, in addition to be approved according to selected international standards.

The helmet properties will be evaluated through a test protocol which aims to trigger the development of helmets offering an optimal protection for riders. An optimal protection is understood as providing a minimised risk of skull fracture and of the multiple forms of brain damage, as well as a measured and controlled mechanical performance of the protective padding and the shell.

The FIM test approach will first assess the helmet response to very high and medium-low severity linear impacts, randomly in 13 out of 22 pre-established locations distributed all over the helmet surface. This aims at evenly assessing the level of protection against skull fracture and at featuring the mechanical properties of the protective padding (or liner).

Innovatively, the FIM test procedure will then pioneer the assessment of the helmet response to medium severity oblique impacts, aiming at evaluating the level of protection against brain injuries generated by critical rotational accelerations. The oblique test constitutes the most novel and modern aspect of the methods of testing and reflects a very common scenario occurring in real world accidents, although never addressed in international standards so far.

In addition, a penetration test will be included in the protocol and used to check the shell resistance to impacts against sharp objects.

FIM Homologated helmets will be required in all Circuit Racing FIM World Championships and Prize events as of 2019. The homologation will allow the FIM to ensure a more complete and high-end protection for its riders and in particular to better track and control helmets used in FIM competitions. It will also tend to preserve the interests of the homologated helmets' manufacturers. The FIM is hopeful that the new testing protocol can evolve still further, while serving as an inspiration for and cascading to international standards for road use.

This document was prepared under the direction of the FIM International Technical Commission, in collaboration with the Laboratory of Impact of the University of Zaragoza and leading road helmet manufacturers. The document provides the TECHNICAL

INFORMATION AND CRITERIA, the TERMS AND CONDITIONS and the APPLICATION FORM, for interested parties wishing to apply to the Programme.

This document may be subject to amendments as determined by the FIM.

## II. SCOPE

Eligibility of the FIM racing homologated Model, Size and combination of accessories to be used as from 2019 at FIM World Championship, Cup & Prize events as listed in below

- FIM Grand Prix World Championship
- FIM Superbike World Championship
- FIM Supersport World Championship
- FIM Sidecar World Championship
- Red Bull FIM MotoGP Rookies Cup
- FIM Supersport 300 World Championship
- FIM CEV Repsol Moto3 Junior World Championship
- FIM MotoE World Cup
- FIM World Record Attempts
- FIM Drag Bike World Cup
- FIM Endurance World Championship
- FIM Endurance World Cup

For further information concerning the events at which FIM racing homologated helmets are mandatory, please refer to the specific Regulations yearly issued for each World Championship, Cup or Prize.

## III. TECHNICAL INFORMATION AND CRITERIA (FIM HELMET STANDARD)

### III.1 ELIGIBLE HELMETS

A helmet is eligible for homologation if it is certified compliant with at least one of the following standards:

- UNECE 22.05 Type P
- Snell M 2015
- JIS T8133 2015 Type 2 Full face

Moreover, eligible helmets must meet the following requirements:

- a protective lower face cover must be present and must be not detachable or moveable;
- the shell needs to be constructed in one piece (example: without any seam);
- a retention system with a strap and the double D-ring closing system must be present.

## III.2 TESTING PROCEDURES

The test procedures of the present document are mainly based on UNECE 22.05.

The FRHPhe homologates a range of Sizes (those wished by the Applicant) of a specific Helmet Model, if all the test results fulfil the conditions as defined hereinafter. Within one Size, the homologation is valid for one or more Combination(s) of accessories and not for others (see hereinafter).

Testing procedures described in this document imply the use of 10 Helmet Samples per Size and per Combination of accessories, distributed in the different test phases as follows:

- Samples #1, #2 and #3: Conditioning, Weight, Linear impact tests
- Samples #4 and #5: Conditioning, Weight, Oblique impact tests
- Sample #6: Conditioning, Weight, Penetration tests
- Sample #7: Storage
- Sample #8, #9 and #10: Conditioning, Weight, Extra tests if needed

A detailed description of the test phases is given hereinafter.

The helmets are homologated per Size and per declared Combination of accessories (e.g. aerodynamic devices). The Applicant shall declare all accessories that will be fitted to the helmet and how they will be combined for use. As a general rule, all declared Combinations of the declared accessories will be tested within the same homologation. The same Combinations of accessories shall be used at the events as reported in II SCOPE.

The Applicant shall declare the cover paint and the comfort padding used.

The correspondence between the Helmet Size and the corresponding EN960:2006 headform to be used in the test shall be according to Table 1.

Helmets of Size 50 cm or smaller shall be tested with the headform "A". Helmets of Size 62 cm or larger shall be tested with the headform "O".

		Largest Size specified (cm)													
		50	51	52	53	54	55	56	57	58	59	60	61	62	
Smallest Size Specified (cm)	50	A	A	C											
	51		C	C	C										
	52			C	C	E									
	53				E	E	E								
	54					E	E	E							
	55						E	E	J						
	56							J	J	J					
	57								J	J	J				
	58									J	J	M			
	59										J	M	M		
	60											M	M	M	
	61												M	O	
	62													O	

Table 1: Correspondence between tested headforms and Helmet Sizes

## III.2.1 SAMPLES #1, #2 AND #3: LINEAR IMPACT TESTS

This set of tests is designed to measure the impact absorption capacity of helmets. While the tests on Sample #1 and #2 focus only on the assessment of the protection against skull fracture and the mechanical characterization of the liner, the test on Sample #3 assesses the level of protection against brain damage, using more recent biomechanical bases.

A total of 13 linear impact tests shall be performed according to UNECE 22.05 7.3 (impact-absorption tests) with the following inclusions or modifications:

### III.2.1.1. Helmet conditioning and weight

After solvent conditioning (as defined in UNECE 22.05 7.2.1), the Samples shall be stored in an atmosphere with a temperature of  $(25 \pm 5)^{\circ}\text{C}$  and a relative humidity of  $(50 \pm 20)\%$  for a period of not less than 4h. No further conditioning is required prior to test. The weight of the helmet fitted with the corresponding Combination of accessories as it will be used in competition (such as ventilation devices, aerodynamics devices, ear cups, etc.) and with standard paint shall be measured and recorded.

### III.2.1.2. Headforms

A set of headforms defined as follows shall be used:

- the external dimensions shall be according to EN960:2006
- the resonance frequency shall be according to EN960:2006
- the mass shall be according to EN960:2006 (instrumentation included)
- the position of the centre of gravity shall be according to EN960:2006

The headform inertia matrix of reference for the homologation is according to Table 2 (principal directions only, with regards to the centre of gravity):

Headform denomination	Circumference [mm]	Mass [Kg]	Ixx [Kg cm <sup>2</sup> ] ( $\pm 5\%$ )	Iyy [Kg cm <sup>2</sup> ] ( $\pm 5\%$ )	Izz [Kg cm <sup>2</sup> ] ( $\pm 5\%$ )
A	495*	3.1 ( $\pm 0.10$ )	142.2	166.6	95.0
C	515*	3.6 ( $\pm 0.10$ )	172.6	203.3	113.2
E	535*	4.1 ( $\pm 0.12$ )	202.9	238.6	141.3
J	575*	4.7 ( $\pm 0.14$ )	264.0	318.3	193.1
M	605*	5.6 ( $\pm 0.16$ )	337.4	402.7	252.7
O	625*	6.1 ( $\pm 0.18$ )	383.6	461.1	293.5

\*Tolerances according to UN 960:2006

Table 2: Properties of the headforms



### III.2.1.3. Positioning of the helmet

The headform shall be positioned inside the helmet according to the following instructions:

- Head Positioning Index (HPI): the headform shall be positioned inside the helmet respecting the HPI as declared by the Applicant; the HPI shall respect the requirements of annex 5 of UNECE 22.05;
- Chinstrap tension: the retention system shall be adjusted under the chin of the headform and tightened to a tension of  $75 \pm 5$  [N] (over strap friction) with a deflection angle of  $45 \pm 5^\circ$ .

Before each impact, the helmet shall be re-positioned according to the HPI and the retention system re-tensioned.

### III.2.1.4. Measuring assembly

Headforms shall be fitted with an assembly of instruments containing a set of 3 linear accelerometers and 3 angular rate sensors, located at their centre of gravity.

The assembly shall enable the measurement at the centre of gravity of the three components of the linear acceleration ( $a_x, a_y, a_z$ ) and the angular rate ( $\omega_x, \omega_y, \omega_z$ ) over time.

The 3 linear accelerometers shall be oriented in the three natural directions of the headform. The accelerometers shall be capable of withstanding a maximum acceleration of 2000 [g] without damage. The acceleration data shall be sampled at a frequency of 10000 Hz and filtered in accordance with the latest edition of ISO 6487 (CFC 1000).

The angular rate sensors shall have a measurement capacity of 8000 [deg/s], between 0 and 2000 [Hz]. The angular velocity data shall be sampled at a frequency of 10000 [Hz] and filtered in accordance with the latest edition of ISO 6487 (CFC 180).

### III.2.1.5. Anvil

Only a flat steel anvil shall be used, with a circular impact face of diameter  $130 \pm 3$  [mm].

### III.2.1.6. Impact sites and speed

#### *UNECE 22.05 POINTS*

5 linear impact tests in points B, X, P, R and S (according to UNECE 22.05 7.3.4.2) shall be performed in this sequence on Sample #1 and Sample #3. Only one impact per site shall be performed.

#### *"EXTRA" POINTS*

3 impact tests shall be performed on Sample #2. The impact points shall be selected among the 12 points as listed below and depicted in Figure 1, respecting the indicated order. The selected impact points shall not be less than 120 [mm] apart.

BP, in the front-superior area, situated in the vertical longitudinal plane of symmetry of the helmet ( $0^\circ$ ) and at a midpoint between the point B and the point P.

- BXL, in the left (315°) front-lateral area, situated in the vertical plane and at an angle of 20° measured from Z above the AA' plane.
- BXR, in the right (45°) front-lateral area, situated in the vertical plane and at an angle of 20° measured from Z above the AA' plane.
- BXPL, in the left (315°) front-lateral-superior area, situated in the vertical plane and at a midpoint between the point BX and the point P.
- BXPR, in the right (45°) front-lateral-superior area, situated in the vertical plane and at a midpoint between the point BX and the point P.
- XPL, in the left (270°) lateral-superior area, situated in the central transverse vertical plane and at a midpoint between the point X and the point P.
- XPR, in the right (90°) lateral-superior area, situated in the central transverse vertical plane and at a midpoint between the point X and the point P.
- RXL, in the left (225°) rear-lateral area, situated in the vertical plane and at an angle of 20° measured from Z above the AA' plane.
- RXR, in the right (135°) rear-lateral area, situated in the vertical plane and at an angle of 20° measured from Z above the AA' plane.
- RXPL, in the left (225°) rear-lateral-superior area, situated in the vertical plane and at a midpoint between the point RX and the point P.
- RXPR, in the right (135°) rear-lateral-superior area, situated in the vertical plane and at a midpoint between the point RX and the point P.
- RP, in the rear-superior area, situated in the vertical longitudinal plane of symmetry of the helmet (180°) and at a midpoint between the point R and the point P.

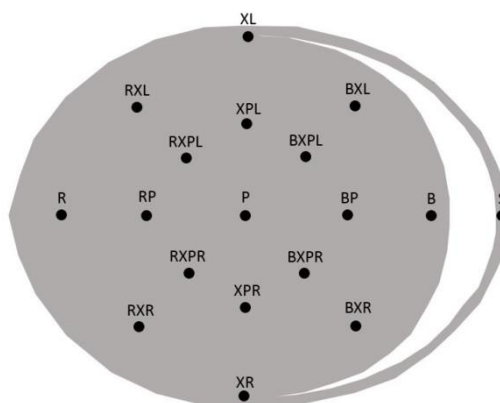

Figure 1: Identification of extra points

Impacts at points shall be within 10 [mm] radius of the defined point.

The test headform shall be positioned so that the designated point of the helmet is vertically above the centre of the anvil. The plane tangential to the point of impact shall be

horizontal. This prescription does not apply for the S impact point. When testing impact point S, the impact point shall be not less than 15 [mm] from the rim.

The drop height shall be such to obtain an impact speed of:

- 8.20 (+0.15, -0.0) [m/s] for points B, X, P and R on Sample #1
- 6.00 (+0.15, -0.0) [m/s] for point S on Sample #1
- 8.20 (+0.15, -0.0) [m/s] for the "extra" points on Sample #2
- 5.00 (+0.15, -0.0) [m/s] for points B, X, P, R and S on Sample #3

The velocity of the moving mass shall be measured between 1 cm and 6 cm before impact, to an accuracy of 1%.

#### g) Acceptance criteria

The peak of the resultant linear acceleration (*PLA*) values (measured at the center of gravity of the headform) shall not exceed 275 [g] in all impact sites on Sample #1 and #2, 208 [g] on Sample #3.

The Head Injury Criterion (*HIC*) shall not exceed the value of 2880 in all impact sites on Sample #1 and #2, 1300 on Sample #3.

### **III.2.2 SAMPLE #4 AND #5: OBLIQUE IMPACT TEST**

The objective of this test is to measure, in fully repeatable conditions, the capacity of the helmet to absorb and damp rotational solicitations generated in impacts combining normal and tangential forces.

The test is based on a standard impact-absorption test, with a particular type of anvil and dropping speed. The test is conceived to be performed by using the same headforms of the linear impact test, instrumented with the same sensors.

A total of 5 oblique tests shall be performed similarly to linear impact tests of UNECE 22.05 7.3 (impact-absorption tests) with the following inclusions or modifications:

#### **III.2.2.1. Helmet conditioning and weight**

The same conditioning and weight measurement of the linear impact tests of the present procedure (Samples #1, #2 and #3) shall be applied.

#### **III.2.2.2. Headforms**

The oblique impact test shall use the same set of headforms as defined for the linear impact tests of the present procedure. An external additional coating is applied to the headform before the helmet is placed on the headform to be tested. The coating consists of a thin layer (<0.4 mm) of high performance platinum cure liquid silicone, with the technical data as indicated in Table 3 .

Technical Data of the Coating		
Mixed viscosity	23000	[cps]
Specific gravity	1.07	[g/cc]
Specific volume	25.8	[cu.in./lb.]
Shore A hardness	10	A
Tensile strength	475	[psi]
100% modulus	22	[psi]
Elongation at break %	1000	%
Die B tear strength	102	[pli]
Shrinkage	<0.001	[in./in.]

Table 3: Properties of the additional coating

### III.2.2.3. Positioning of the helmet

The headform shall be positioned inside the helmet in the same way as for the linear impact test of the present procedure.

### III.2.2.4. Measuring assembly

The measuring assembly shall be the same as the one used for the linear impact tests of the present procedure.

### III.2.2.5. Anvil

A so called "oblique anvil" shall be used. This type of anvil shall consist of a solid cylinder of diameter  $130 \pm 3$  [mm] with an impact face consisting of a section at  $45 \pm 0.5$  [°] with respect to its longitudinal axis, covered in abrasive paper. The abrasive paper shall be a sheet of grade 80 closed-coat aluminium oxide abrasive paper. The abrasive paper shall be replaced after significant damage (up to 3 tests).

### III.2.2.6. Impact sites and speed

Impacts shall be performed in correspondence of the 5 sites as depicted in Table 4 and Table 5. Only one impact per site shall be performed. Helmet Sample #4 is used for front-lateral right (45°), rear (180°) and lateral left (270°), while Helmet Sample #5 is used for front (0°) and rear-lateral right (135°).

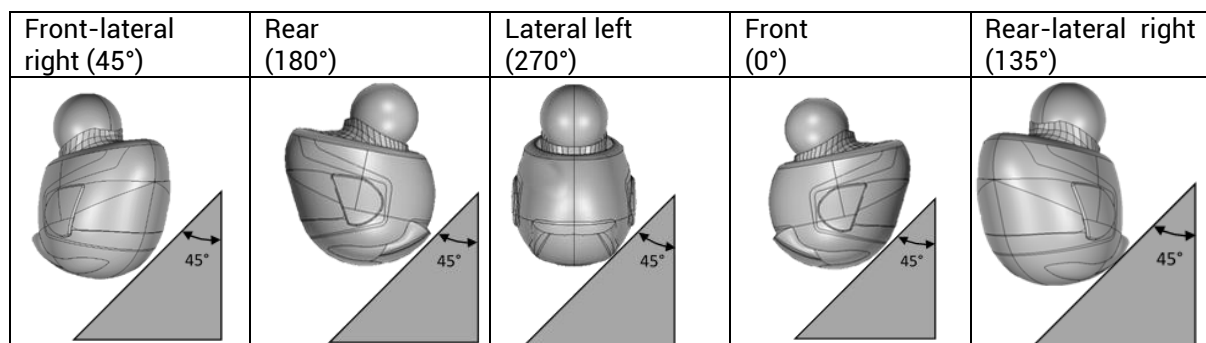

Table 4: Impact layouts for the oblique test: SIDE VIEW

Front-lateral right (45°)	Rear (180°)	Lateral left (270°)	Front (0°)	Rear-lateral right (135°)
				

Table 5: Impact layouts for the oblique test: TOP VIEW

Impacts at points shall be within 10 [mm] radius of the defined point.

The test headform shall be positioned so that the designated point of the helmet is vertically above the centre of the anvil. For all oblique impact layouts, the central vertical axis of the headform shall be aligned to the vertical with a tolerance of  $\pm 0.5$  [°].

The drop height shall be such to obtain an impact speed of 8.00 (+0.15, -0.0) [m/s]. In a 45 [°] anvil, this speed gives the following normal ( $V_N$ ) and tangential ( $V_T$ ) components:

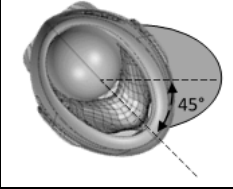
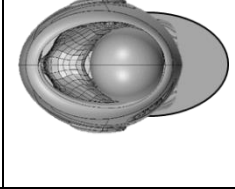
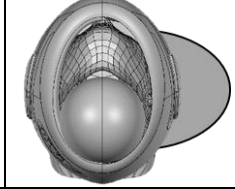
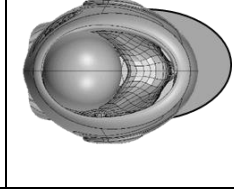
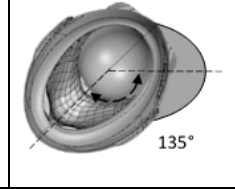
- $V_N = 5.66$  [m/s]
- $V_T = 5.66$  [m/s]

The velocity of the moving mass shall be measured between 1 [cm] and 6 [cm] before impact, to an accuracy of 1%.

### III.2.2.7. Acceptance criteria

The peak of the resultant linear acceleration (*PLA*) values (measured at the center of gravity of the headform) shall not exceed 208 [g] in all impact sites on Sample #4 and #5.

The Head Injury Criterion (*HIC*) shall not exceed the value of 1300 in all impact sites on Sample #4 and #5.

The peak of the resultant rotational acceleration (*PRA*) shall be calculated differentiating the rotational velocity values. The *PRA* shall not exceed 10400 [rad/s<sup>2</sup>] in all impact sites on Sample #4 and #5.

The injury predictor so called as Brain Injury Criterion (*BrIC*) shall be also calculated as follows:

$$BrIC = \sqrt{\left(\frac{\omega_x}{\omega_{xC}}\right)^2 + \left(\frac{\omega_y}{\omega_{yC}}\right)^2 + \left(\frac{\omega_z}{\omega_{zC}}\right)^2}$$

Where:

- $\omega_x$ ,  $\omega_y$  and  $\omega_z$  are maximum angular rates on X-, Y-, and Z-axis respectively
- $\omega_{xC}$ ,  $\omega_{yC}$  and  $\omega_{zC}$  are the critical angular velocities in their respective directions:
  - $\omega_{xC} = 66.25$  [rad/s]
  - $\omega_{yC} = 56.45$  [rad/s]
  - $\omega_{zC} = 42.87$  [rad/s]

The final time of the impact is calculated as the time where the resultant linear acceleration decreases at 5 [g] after its maximum peak.

The resultant value of *BrIC* must have at no time a value exceeding 0.78 during the defined impact time, in all impact sites of Sample #4 and #5.

### **III.2.3 SAMPLE #6: PENETRATION TEST**

The objective of these tests is to ensure the helmet shell integrity.

The testing procedure is in accordance with JIS T8133:2015 5.2 and 7.5 for a Type 2 protective helmet, with the following inclusions or modifications:

#### **III.2.3.1. Helmet conditioning and weight**

The same conditioning and weight measurement of the linear impact tests of the present procedure (Samples #1, #2 and #3) shall be applied.

#### **III.2.3.2. Helmet support**

The support for the helmet being subjected to the penetration test is spherical so as to provide reasonable support for the helmet and conformance with the interior of the helmet immediately beneath the site of the penetration test.

#### **III.2.3.3. Penetration sites**

The penetration test shall be conducted at a minimum of 2 points located at any site on the helmet on or above the "test line" as defined by Snell M2015. The two points shall be at least 75 [mm] apart from each other.

#### **III.2.3.4. Acceptance criteria**

There must be no contact between the striker tip and the spherical support surface in all the tests.

### **III.2.4 SAMPLE #7: STORAGE**

Sample #7 is the so called "reference helmet". The helmet is stored for reference.

### **III.2.5 SAMPLE #8, #9 AND #10: EXTRA TESTS**

Sample #8, #9 and #10 shall be used for extra tests if needed.

### III.2.6 SUMMARY OF ACCEPTANCE CRITERIA

A Helmet Model and Size is granted homologation (with the declared Combinations of accessories if any) if it complies with all the criteria in accordance with Table 6.

FRHPhe-01	
<b>Samples #1 and #2</b>	- $PLA \leq 275$ [g] - $HIC \leq 2880$
<b>Sample #3</b>	- $PLA \leq 208$ [g] - $HIC \leq 1300$
<b>Samples #4 and #5</b>	- $PLA \leq 208$ [g] - $HIC \leq 1300$ - $PRA \leq 10400$ [rad/s <sup>2</sup> ] - $BrIC \leq 0.78$
<b>Sample #6</b>	No contact between striker tip and the support surface.

Table 6: Acceptance criteria for FRHPhe-01

Notwithstanding the above, to be granted the homologation, the helmet shall not exhibit (after any of all the prescribed tests) any breakage or deformation that is deemed dangerous by the FIM.

#### IMPORTANT NOTICE

The present Technical information and criteria will be updated in the future (FRHPhe-02) according to the provisional acceptance criteria (Table 7). The application of the new standard is not defined yet and will be announced in advance on our website [www.frhp.org](http://www.frhp.org).

FRHPhe-02	
<b>Samples #1 and #2</b>	- $PLA \leq 275$ [g] - $HIC \leq 2400$
<b>Sample #3</b>	- $PLA \leq 160$ [g] - $HIC \leq 1000$
<b>Samples #4 and #5</b>	- $PLA \leq 160$ [g] - $HIC \leq 1000$ - $PRA \leq 8000$ [rad/s <sup>2</sup> ] - $BrIC \leq 0.6$
<b>Sample #6</b>	No contact between striker tip and the support surface.

Table 7: Provisional acceptance criteria for FRHPhe-02

The aforementioned thresholds may be adjusted by FIM if changes notably in headforms and/or the international standards of reference and/or other important features of the FIM Helmet Standard FRHP-02 are implemented.

## V. APPLICATION FORM (HOMOLOGATION) / FRHPhe-01

To be filled in for each Helmet Model\* and returned by e-mail to [frhp@fim.ch](mailto:frhp@fim.ch)

*\*If a Helmet Model exists in different versions (corresponding to one or more international standards), an individual application must be done for each version with its relative Sizes and Combinations of accessories.*

<b>(1) Applicant's information</b>	
(1.1) Name	
(1.2) Address (road, city, ZIP code, country)	
(1.3) E-mail	
(1.4) Phone	
(1.5) Commercial trade mark(s)	
(1.6) Contact name	
(1.7) VAT number/Legal registration number	
<b>(2) Manufacturer's information</b>	
(2.1) Name	
(2.2) Address (road, city, ZIP code, country)	
(2.3) E-mail	
(2.4) Phone	
(2.5) Contact name	

<b>(3) Helmet Model</b>		
(3.1) Commercial name(s)		
(3.2) Date of manufacture (mm, yyyy)		
(3.3) Standard(s) under which this helmet is approved (at least one)	UNECE 22.05	n.
	Snell M2015	n.
	JIS T8133 2015	n.
(3.4) Submitted sizes (in cm)		
(3.5) Wished amount of Homologation labels (per size and per year)		



**(Please indicate items for each Helmet Size if they differ)**

<b>(4) Helmet characteristics</b>	
(4.1) Weight (overall, including all accessories and with tolerances)	
(4.2) HPI (Head Positioning Index)	
<b>(4.3) SHELL</b>	
(4.3.1) Thickness(es)	
(4.3.2) Material(s) (matrix, fibre reinforcement, weaving, n. layers)	
(4.3.3) Weight (without accessories, after cutting holes, with tolerances)	
(4.3.4) Production process	
<b>(4.4) COVER PAINT</b>	
(4.4.1) Manufacturer's name	
(4.4.2) Commercial name	
(4.4.3) Type of paint	
(4.4.4) Weight (with tolerances)	
<b>(4.5) ACCESSORIES (e.g. ventilation devices, venturi, spoilers)</b>	
(4.5.1) List of submitted accessories**	
(4.5.2) List of submitted Combinations of accessories***	
(4.5.3) Material(s) (for each accessory)	
(4.5.4) Fixation method (for each accessory)	
<b>(4.6) PROTECTIVE PADDING</b>	
(4.6.1) Material(s)	
(4.6.2) Manufacturer's name	

\*\* Example: front venturi, top vent, rear spoiler

\*\*\* Example: Combination of accessories n.1: front venturi + top vent, Combination of accessories n.2: front venturi + top vent + rear spoiler

(4.6.3) Commercial name	
(4.6.4) Thickness(es)	
(4.6.5) Density(ies)	
(4.6.6) Weight	
<b>(4.7) CHIN GUARD PROTECTIVE PADDING</b>	
(4.7.1) Material(s)	
(4.7.2) Manufacturer's name	
(4.7.3) Commercial name	
(4.7.4) Thickness(es)	
(4.7.5) Density(ies)	
(4.7.6) Weight (with tolerances)	
<b>(4.8) COMFORT PADDING</b>	
(4.8.1) Foam material(s)	
(4.8.2) Fabric material(s)	
(4.8.3) Foam thickness(es)	
<b>(4.9) EXTRA IMPACT MANAGEMEN SYSTEMS (OR OTHERS)</b>	
(4.9.1) Definition	
(4.9.2) Working principle	
<b>(4.10) RETENTION SYSTEM</b>	
(4.10.1) Material(s)	
(4.10.2) Width	
(4.10.3) Anchorage system	

**(5) Documents to be mandatorily annexed (for each Helmet Size if they differ)**

	(5.1) Communication and full test report (including extensions until present date) of at least one of the existing standards (see 3.3) (ECE report is suggested)
	(5.2) Helmet drawings (5.2.1) General views (front, side, rear, top) (5.2.2) Significant sections (including indication of shell and protective padding thicknesses and densities)
	(5.3) Photos (front, side, rear, top and each accessory)

By signing this Application Form (homologation), the undersigned Applicant attests to the accuracy of the information provided and that the Samples submitted (in all Sizes and Combinations of accessories) are fully consistent with the indications set forth on the Application Form.

Applicant's representative

\_\_\_\_\_  
Name

\_\_\_\_\_  
Signature

On \_\_\_/\_\_\_/\_\_\_

## VI. APPLICATION FORM (UPDATE) / FRHPhe-01

To be filled in for each Helmet Model\* and returned by e-mail to [frhp@fim.ch](mailto:frhp@fim.ch)

\*If a Helmet Model exists in different versions (corresponding to one or more international standards), an individual application must be done for each version with its relative Sizes and Combinations of accessories.

(1) Applicant's information		
(1.1) Name		
(1.2) Address (road, city, ZIP code, country)		
(1.3) E-mail		
(1.4) Phone		
(1.5) Commercial trade mark(s)		
(1.6) Contact name		
(1.7) VAT number/Legal registration number		
(2) Manufacturer's information		
(2.1) Name		
(2.2) Address (road, city, ZIP code, country)		
(2.3) E-mail		
(2.4) Phone		
(2.5) Contact name		
(3) History (to be filled by FIM)		
(3.1) Application Form (homologation) of reference		
(4) Helmet Model		
(4.1) Commercial name(s)		
(4.2) Date of manufacture (mm, yyyy)		
(4.3) Standard(s) under which this helmet is approved (at least one)	UNECE 22.05	n.
	Snell M2015	n.
	JIS T8133 2015	n.
(4.4) Submitted sizes (in cm)		
(4.5) Wished amount of Homologation labels (per size and per year)		

**(Please indicate items for each Helmet Size if they differ)**

(5) Reason for update	
(5.1) Update <ul style="list-style-type: none"> <li><input type="radio"/> trademark(s)</li> <li><input type="radio"/> commercial name(s)</li> <li><input type="radio"/> design</li> <li><input type="radio"/> materials and dimensions of the shell (excluding the cover paint)</li> <li><input type="radio"/> materials and dimensions of the protective padding</li> <li><input type="radio"/> materials and dimensions of the accessories (including spoilers)</li> <li><input type="radio"/> others (please specify: _____ _____)</li> </ul>	
(5.2) Other requested information (ex. weight, thickness, materials)	

(6) Tests requested (to be filled in by FIM)		
		Sizes
Sample #1 (linear HS)	Point B	
	Point X (_____)	
	Point P	
	Point R	
	Point S	
Sample #2 (linear HS)	Point ____	
	Point ____	
	Point ____	
Sample #3 (linear LS)	Point B	
	Point X (_____)	
	Point P	
	Point R	
	Point S	
Sample #4 (oblique)	Point 45°	
	Point 180°	
	Point 270°	
Sample #5 (oblique)	Point 0°	
	Point 135°	

Sample #6 (penetration)	Point ____	
	Point ____	
	Point ____	
	Point ____	
	Point ____	

**(7) Samples requested (to be filled by FIM)**

(7.1) Total number of samples requested (per size)

**(8) Documents to be mandatorily annexed (for each Helmet Size if they differ)**

- |       |   |
|-------|---|
| (8.1) | Relevant communication and full test report of at least one of the existing standards (see 3.3) |
| (8.2) | Relevant drawings   |
| (8.3) | Relevant photos   |

By signing this Application Form (update), the undersigned Applicant attests to the accuracy of the information provided and that the Samples submitted (in all Sizes and Combinations of accessories) are fully consistent with the indications set forth on the Application Form.

Applicant's representative

\_\_\_\_\_  
Name Signature

On \_\_\_\_/\_\_\_\_/\_\_\_\_